

# WINGBURG

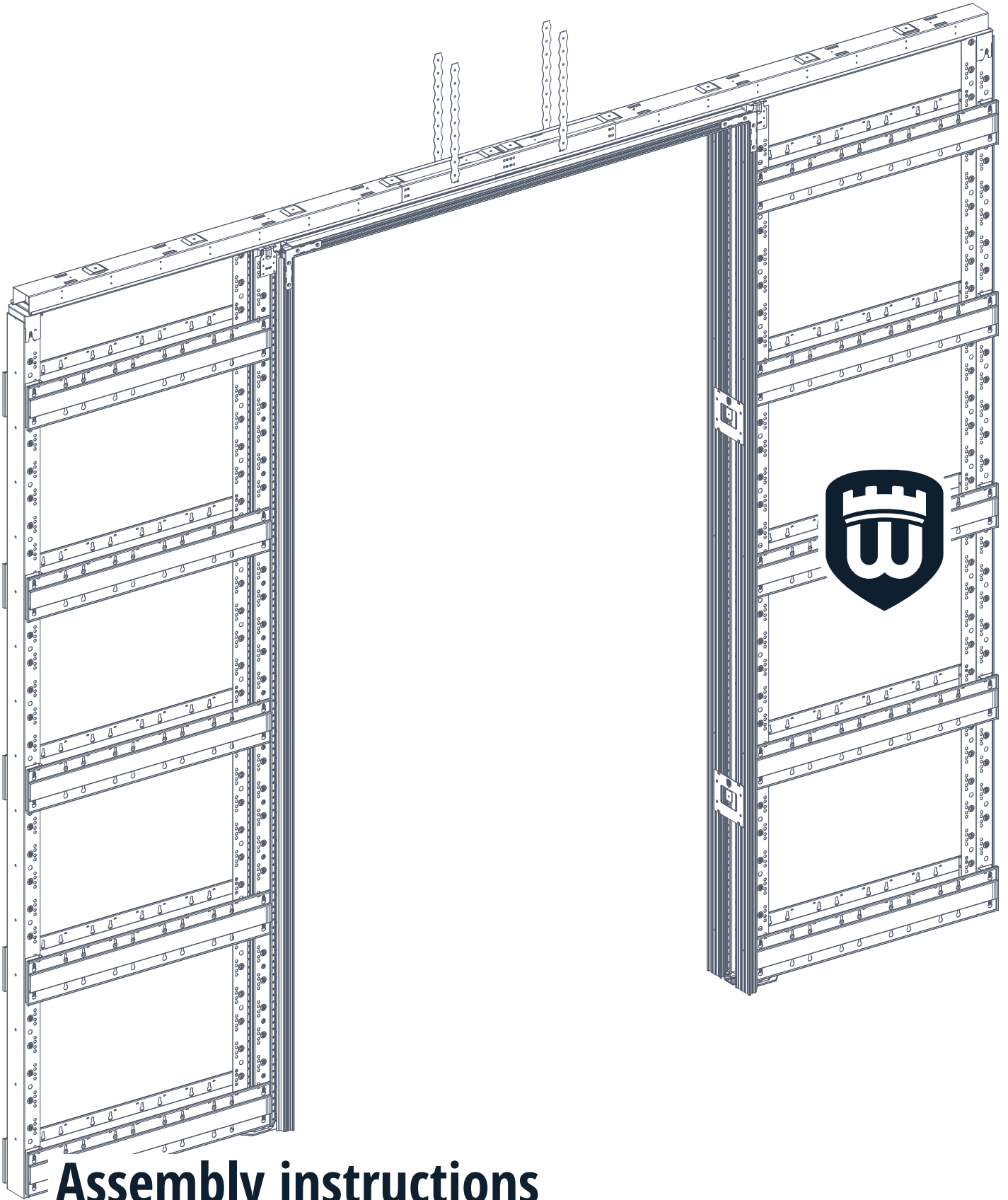

## Assembly instructions

Installation elements for sliding doors

BELPORT **B2T**

Safety instructions	3
Required tools	3
Scope of delivery	4
Assembly CW75	6 - 9
Assembly CW100	10-13
Installation conditions	14
Wall opening	15
Panelling instructions	16
Soffit filling	18

## Safety instructions

---

**D** Vor der Montage, lesen Sie bitte die Montageanleitung sorgfältig. Bei Verständnisschwierigkeiten wenden Sie sich an den Kundendienst oder Ihren Lieferanten. Um das erworbene Produkt fachgerecht montieren zu können, verwenden Sie bitte die auf der folgenden Seite angegebenen Werkzeuge. Da einige Bleche scharfe Kanten aufweisen können, schützen Sie auch unbedingt ihre Hände und Arbeitsflächen vor Schnittverletzungen. Achten Sie während der Montage stets auf eine ergonomische Arbeitsweise und montieren sie nur alleine, wenn Sie eine Gefährdung Ihrer Gesundheit oder anderer Personen ausschließen können. Alle Bauteile wurden vor dem Ausliefern durch „Wingburg“ auf Unversehrtheit überprüft. Für Schäden die auf eine unsachgemäße Montage oder den Transport zurückzuführen sind, übernimmt „Wingburg“ keine Haftung.

**GB** Before installation, please read the instructions carefully. If you have difficulties in understanding the instructions please contact your customer service or your supplier. To assemble the product correctly, please use the tools as indicated on the following page. As some edges maybe sharp we recommend you wear gloves to protect your hands and cover all working surfaces to prevent them from being damaged. Use the correct lifting and carrying techniques during installation. All items have been checked prior to delivery be “Wingburg”. “Wingburg” does not accept any liability for damage that occurs during installation or transportation.

## Required tools

---

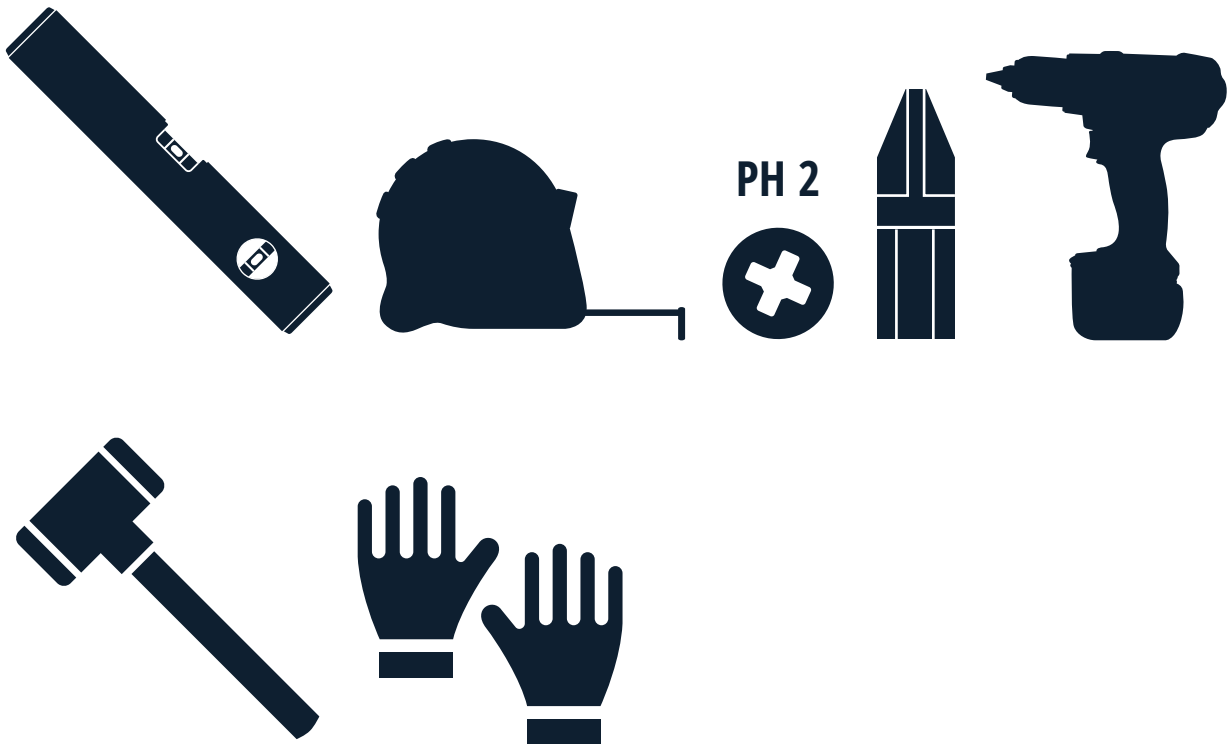

## Components

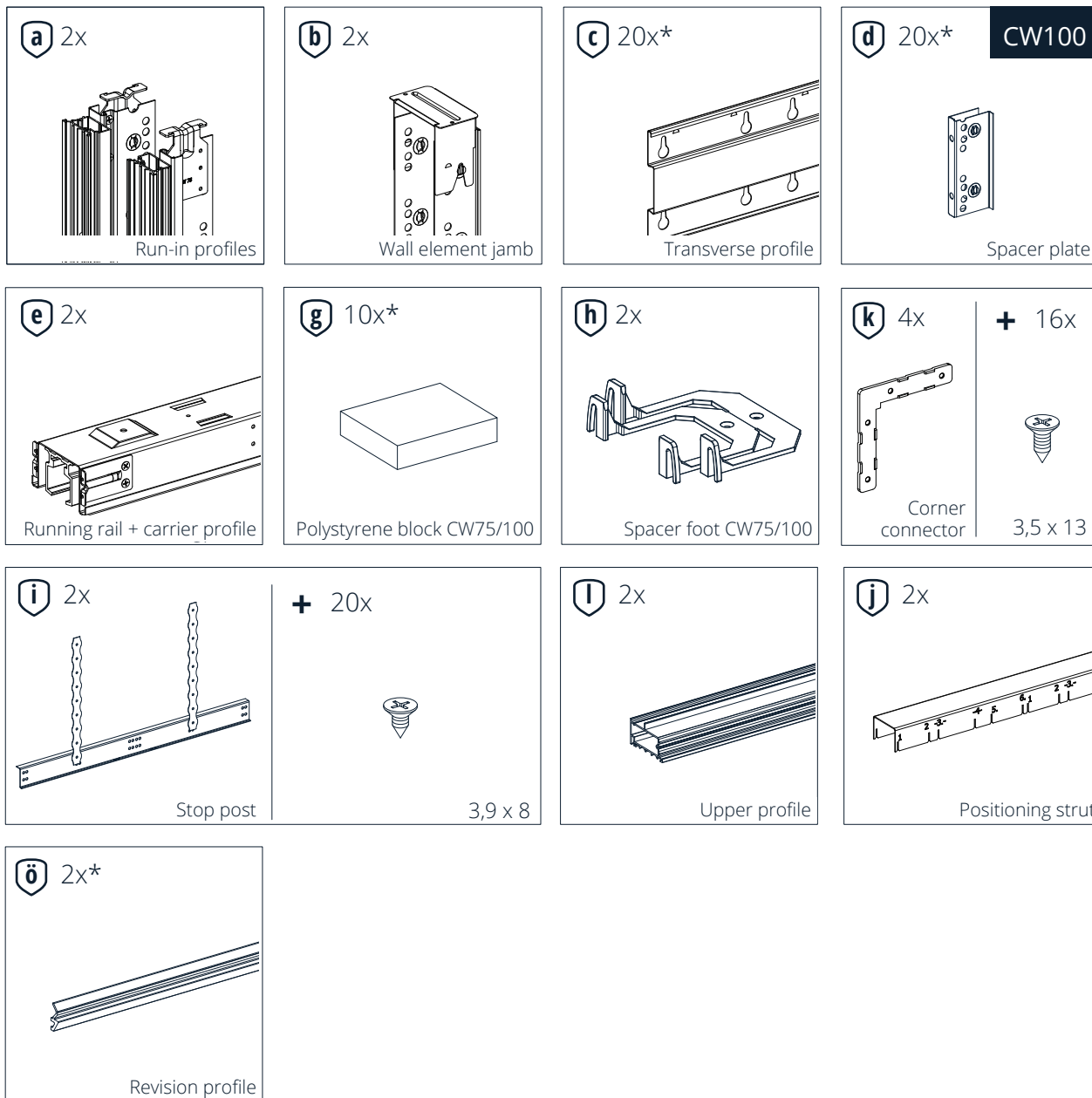

\* The quantity is adapted to the respective installation height of the set and may differ.

## Standard parts



## Miscellaneous

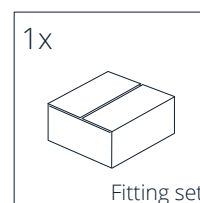



Overview of components

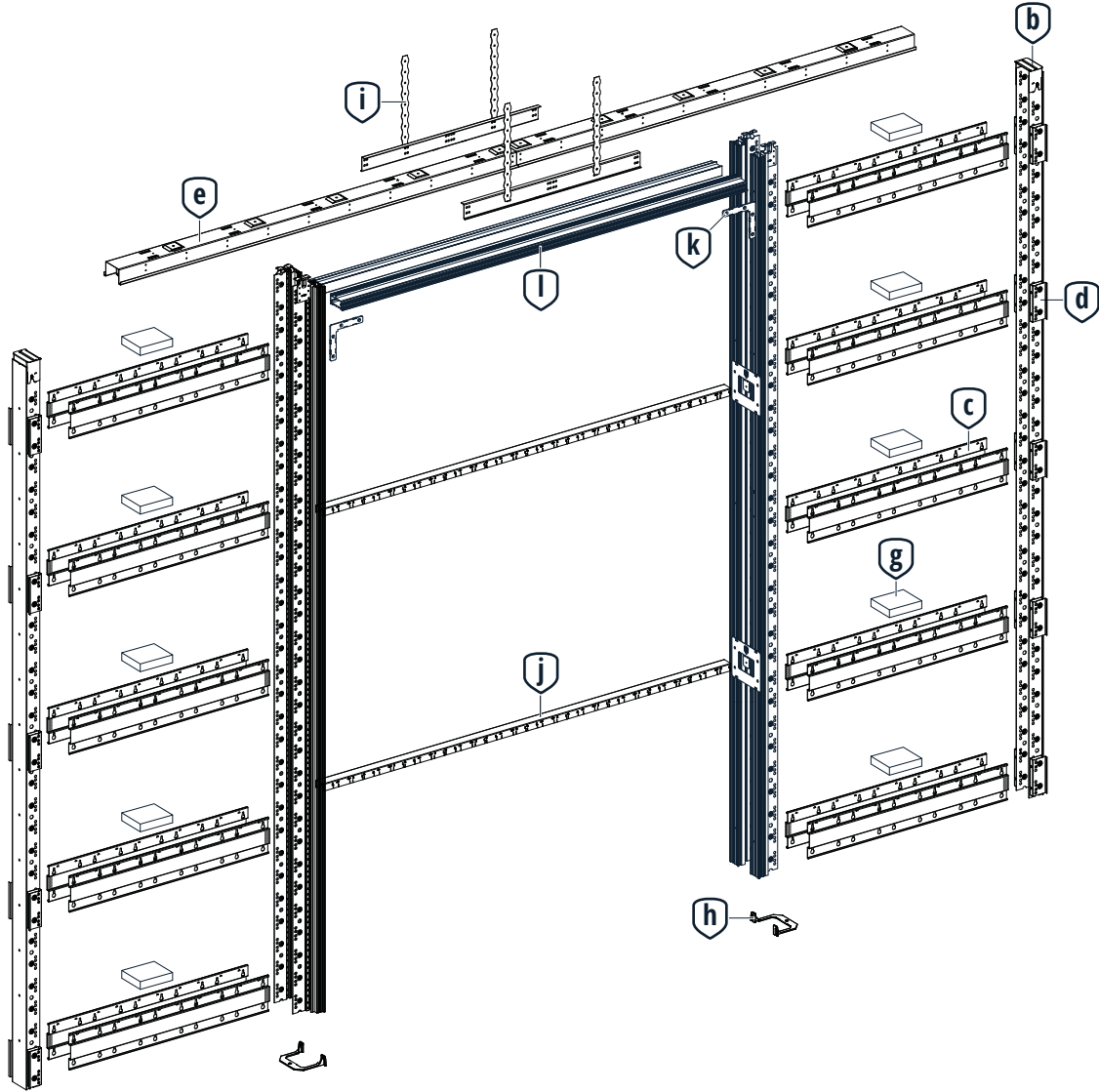

<p><b>CW75</b> profile (condition as supplied) » Assembly from page 6</p>	<p><b>CW100</b> profile (convertible) » Assembly from page 10</p>
<p>Single-planked</p>	<p>Single-planked</p> <p>Not possible</p>
<p>Double-planked</p>	<p>Double-planked</p>

1.

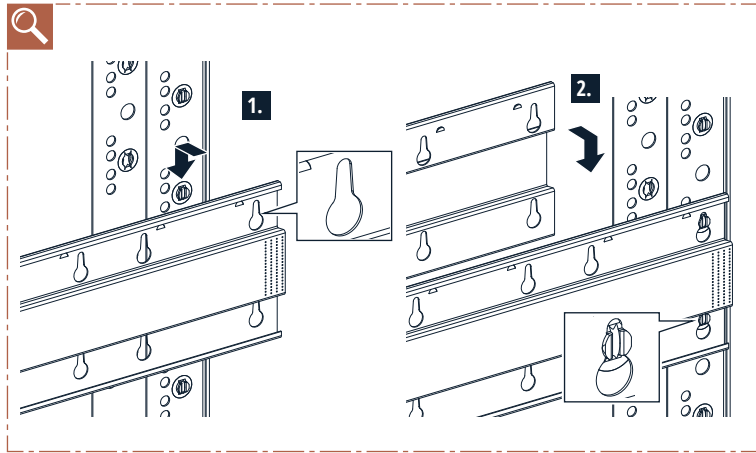
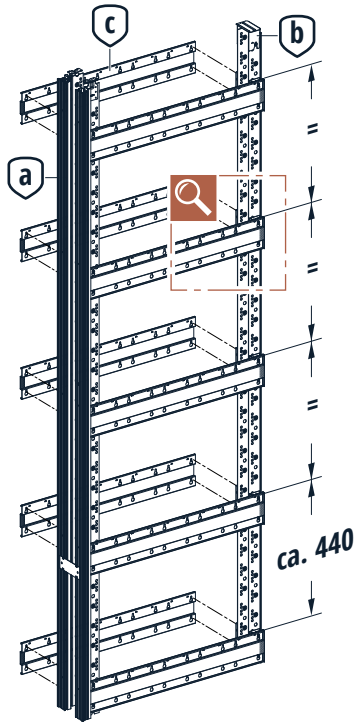

**TIP**

Construction can be facilitated by pre-assembling horizontally

2.

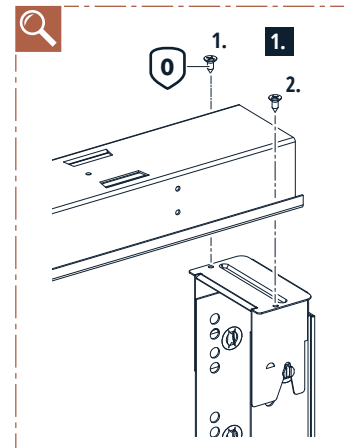
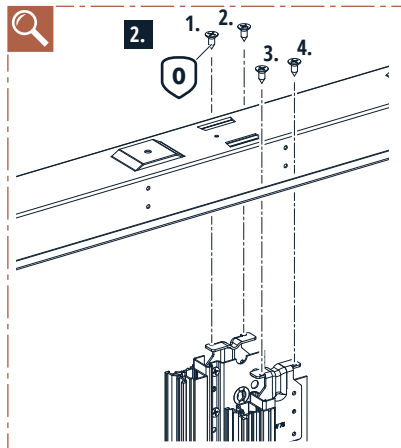
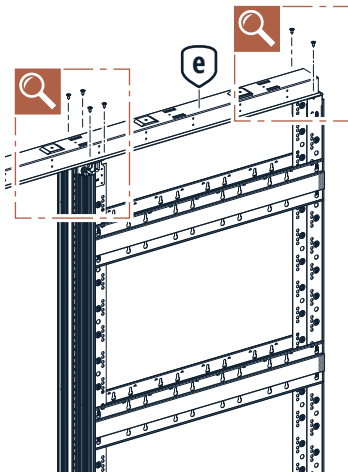

3.

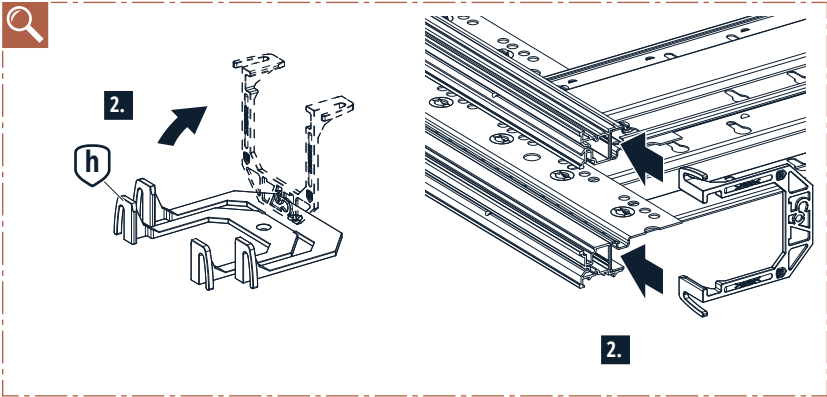
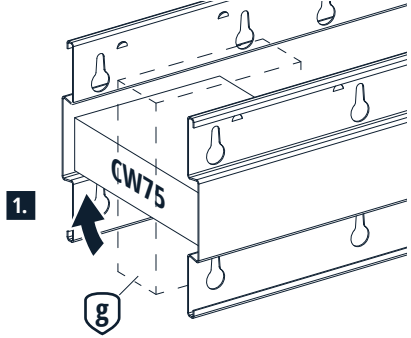
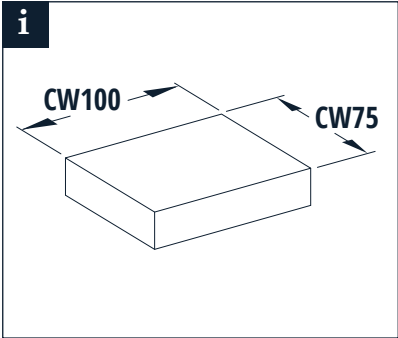
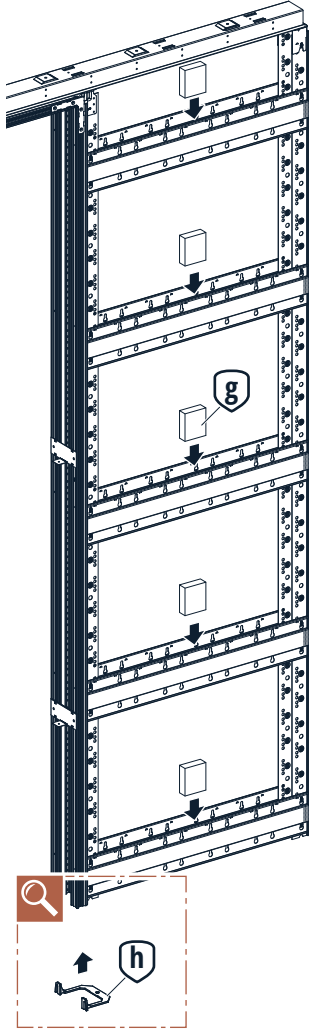

4.

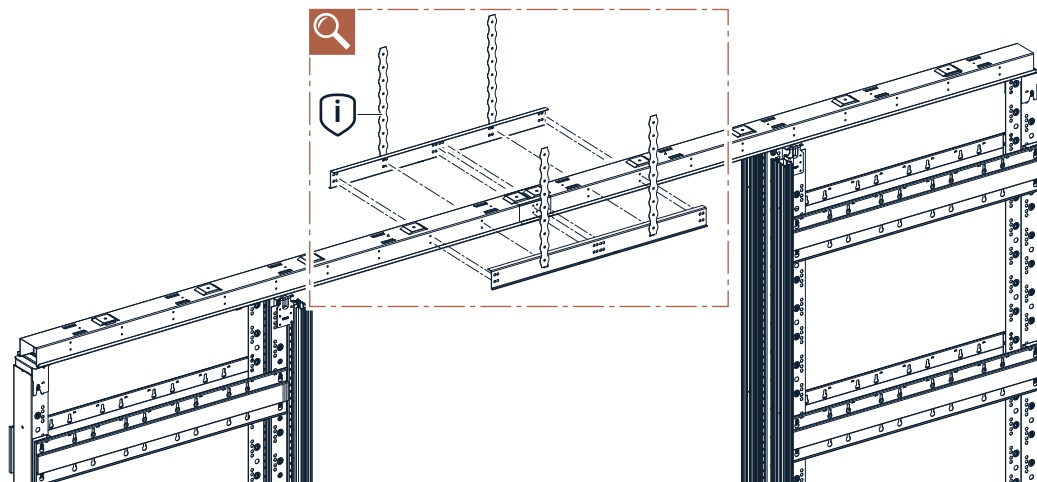
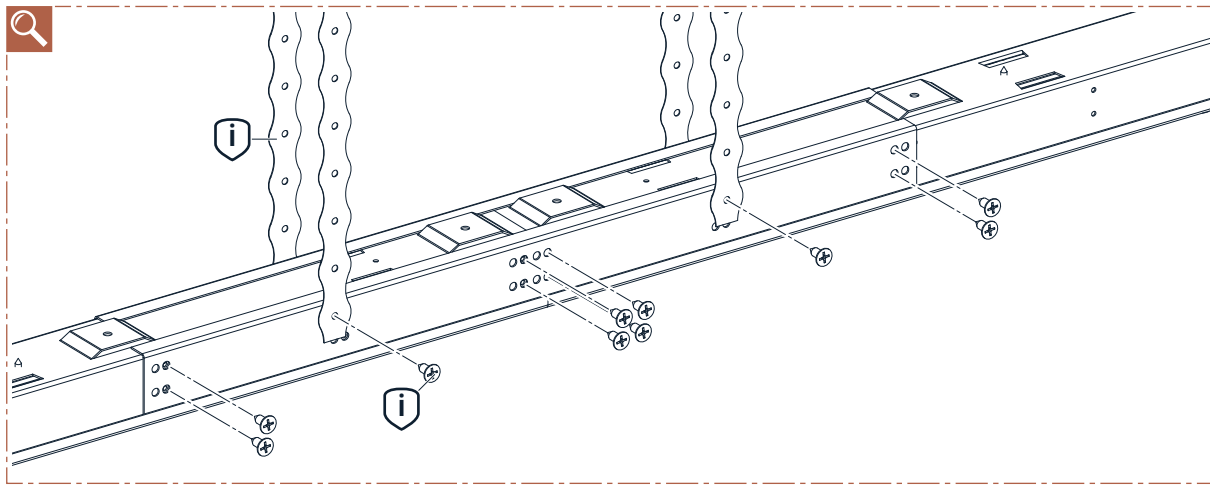

5.

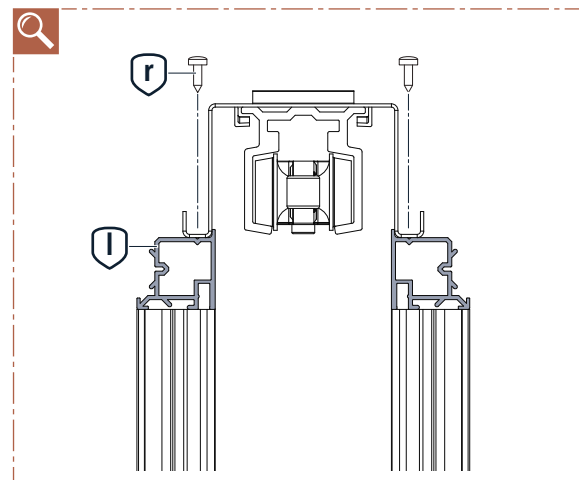
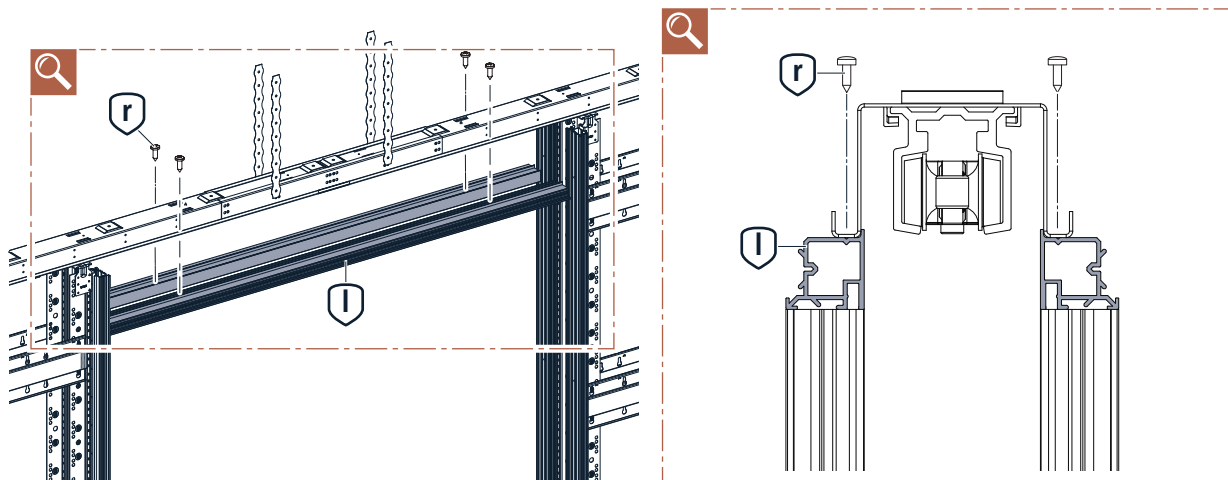

6.

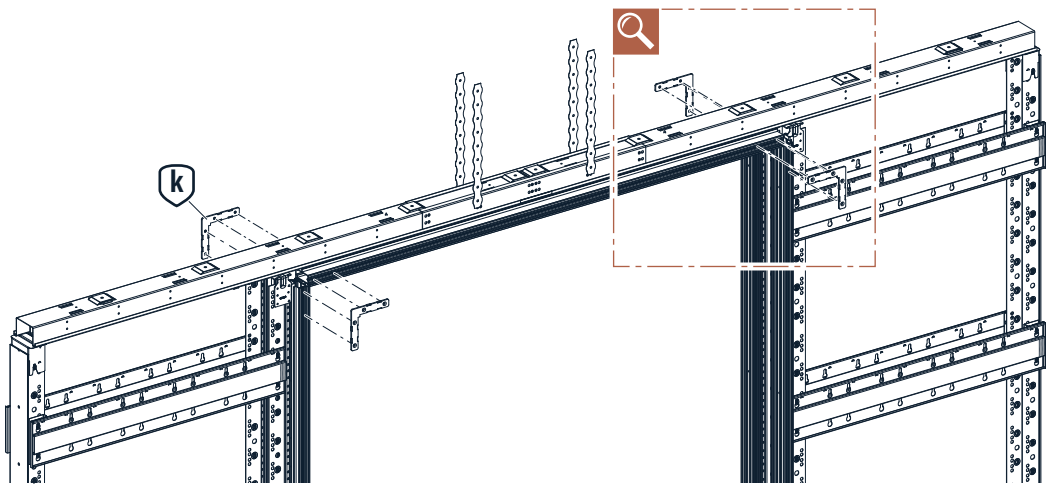
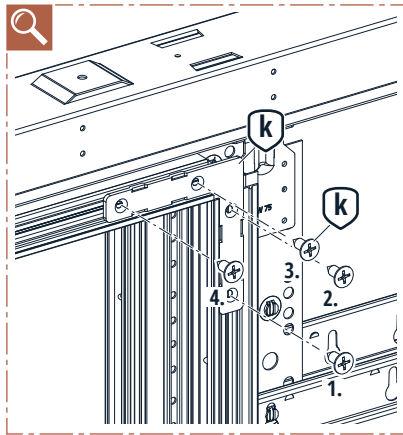

7.

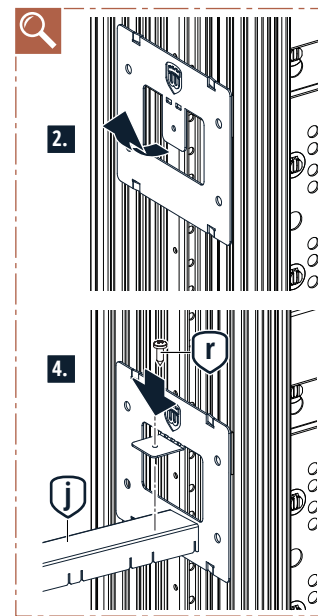
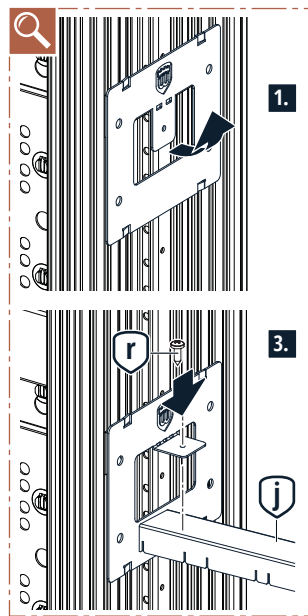
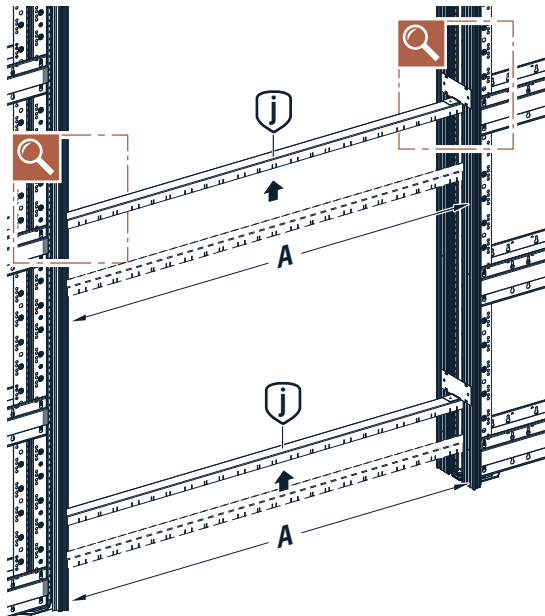

» Continue to step 8 on page 14

1.

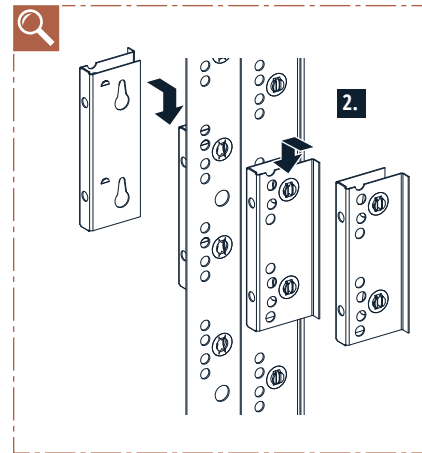
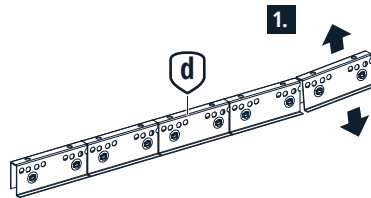
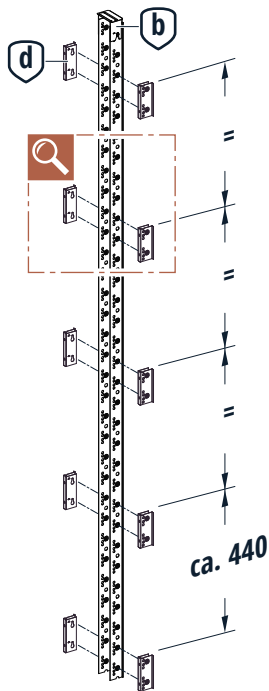

**TIP**  
Construction can be facilitated by pre-assembling horizontally

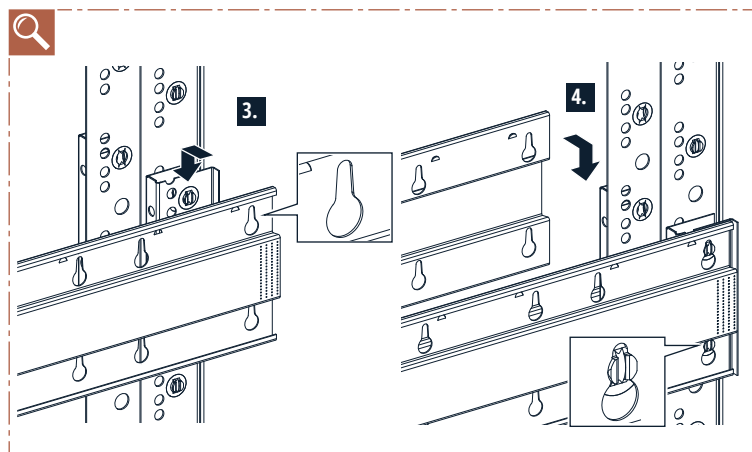
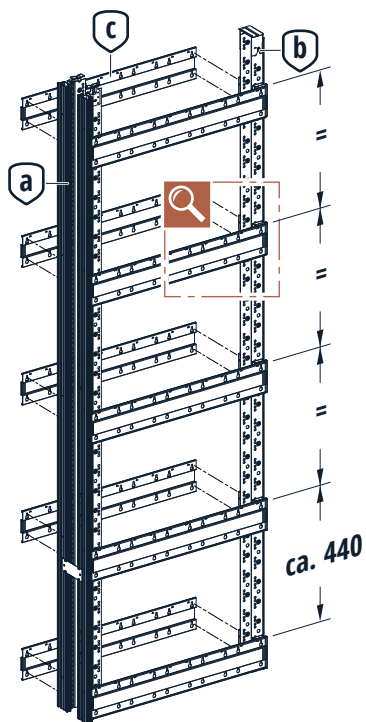

2.

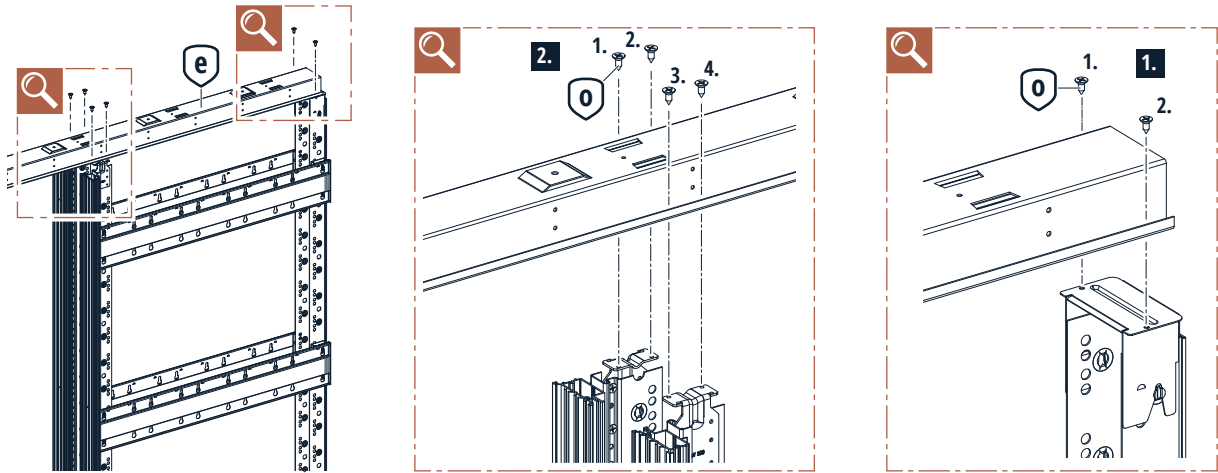

3.

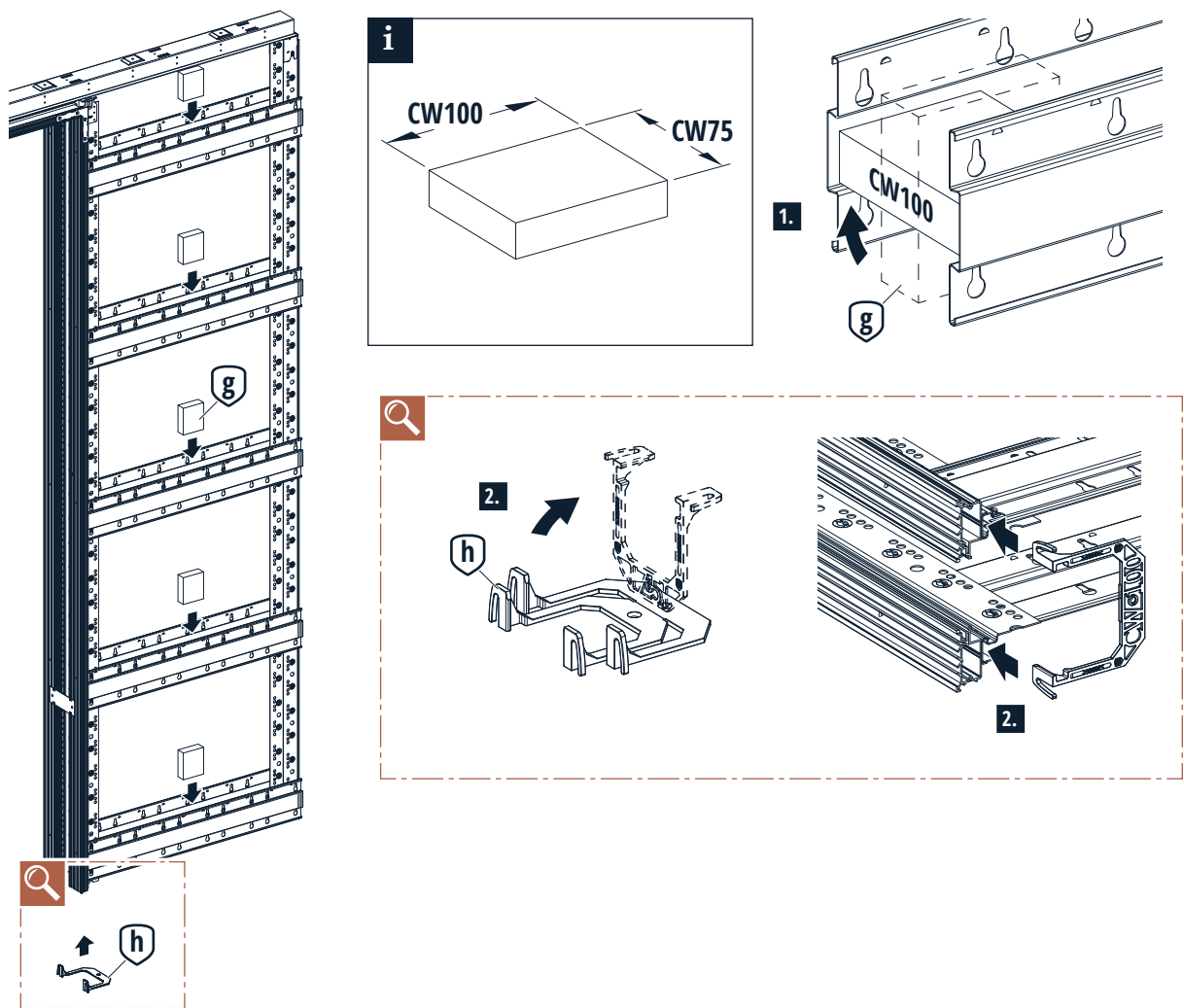



4.

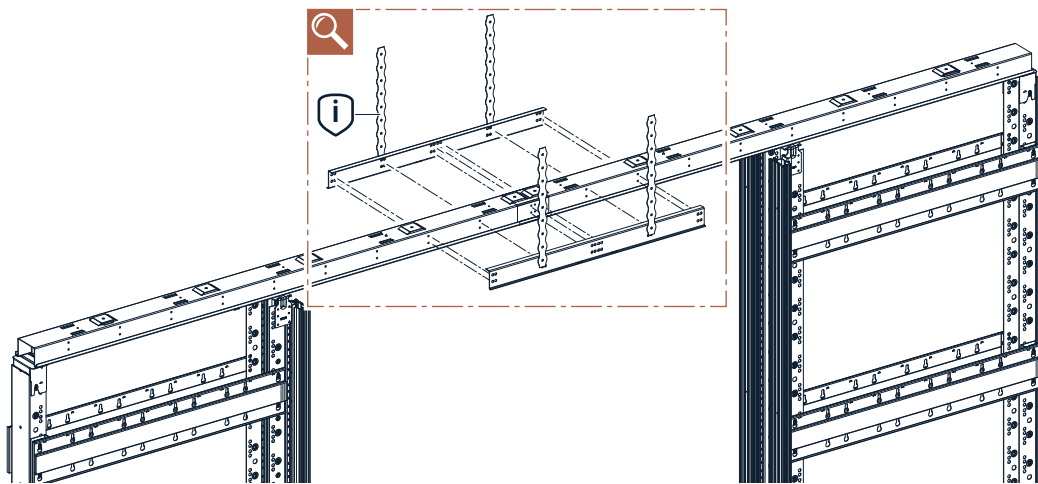
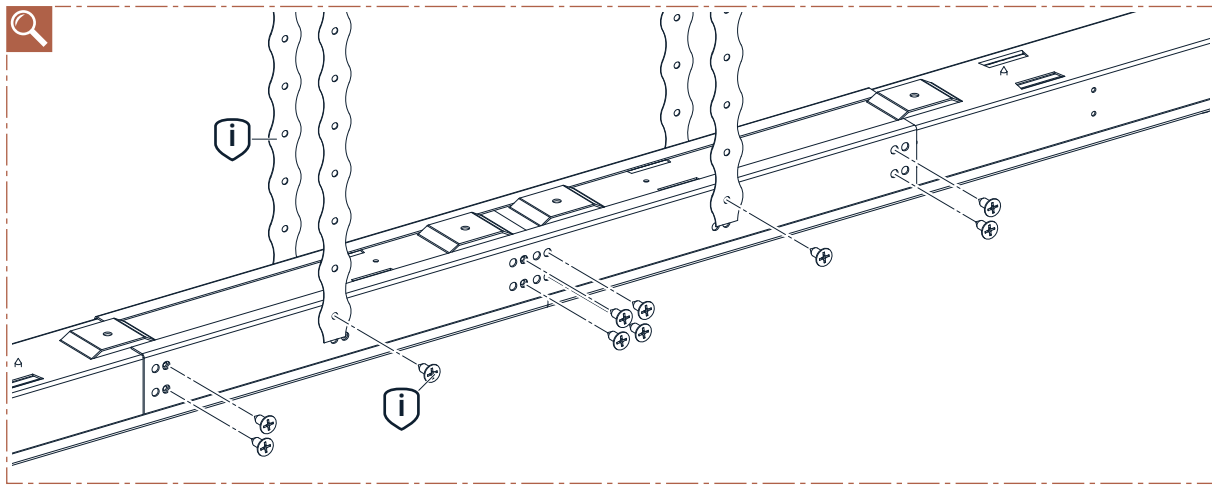

5.

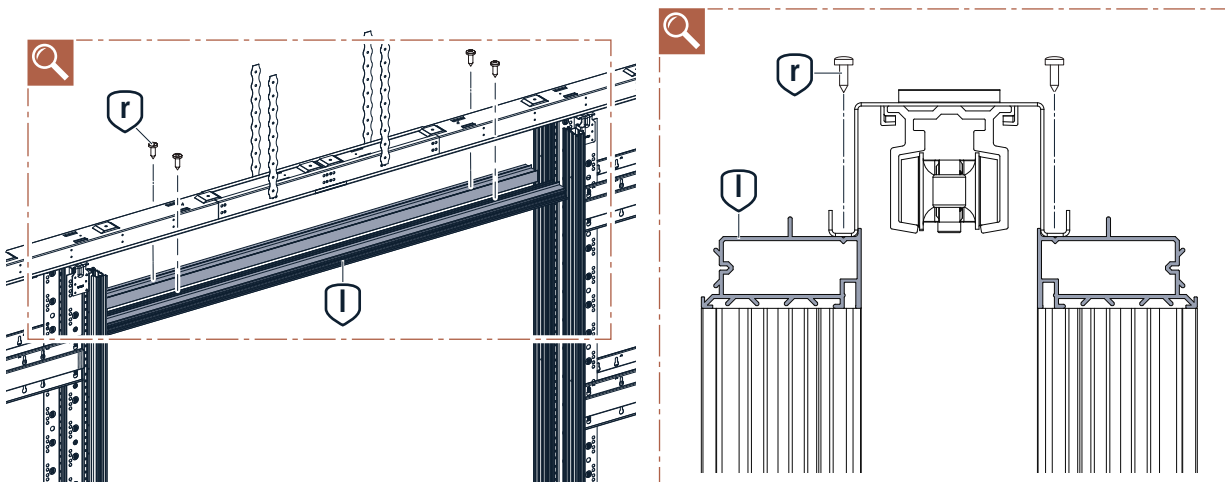



6.

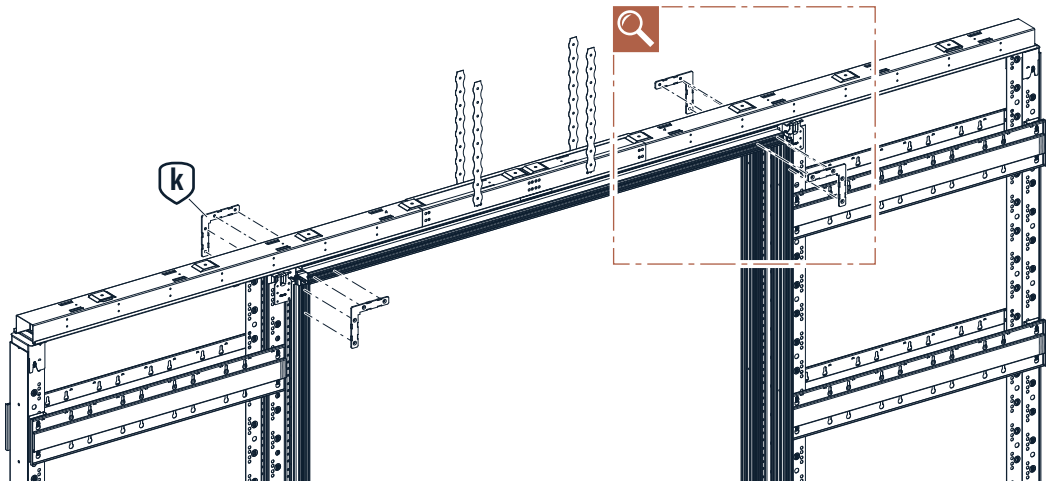
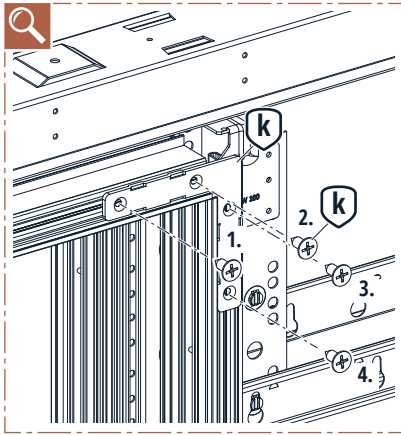

7.

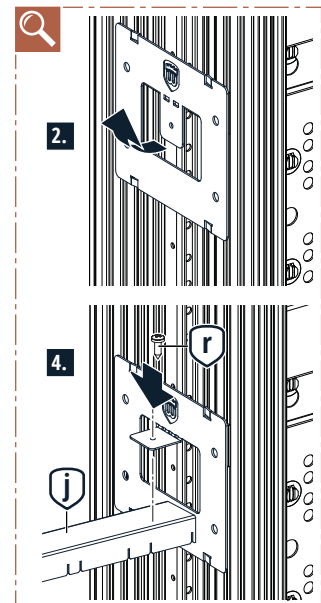
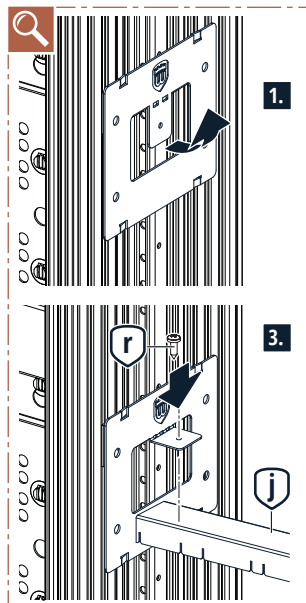
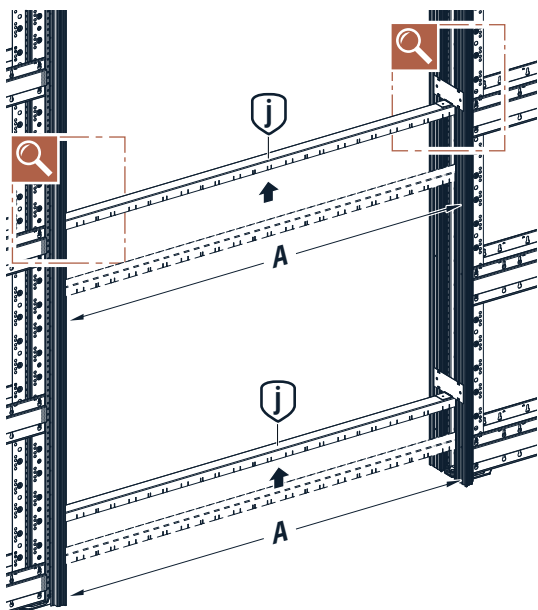

8.

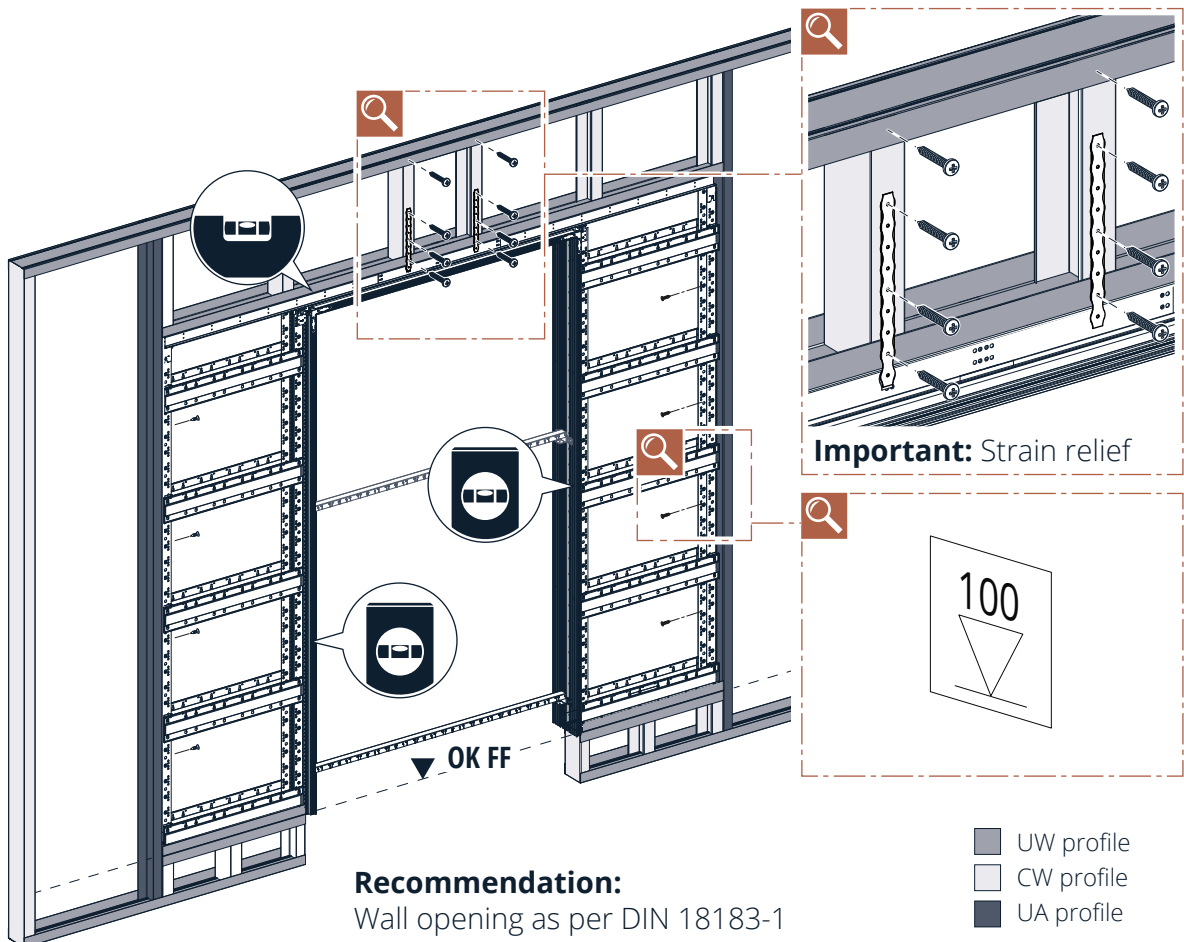
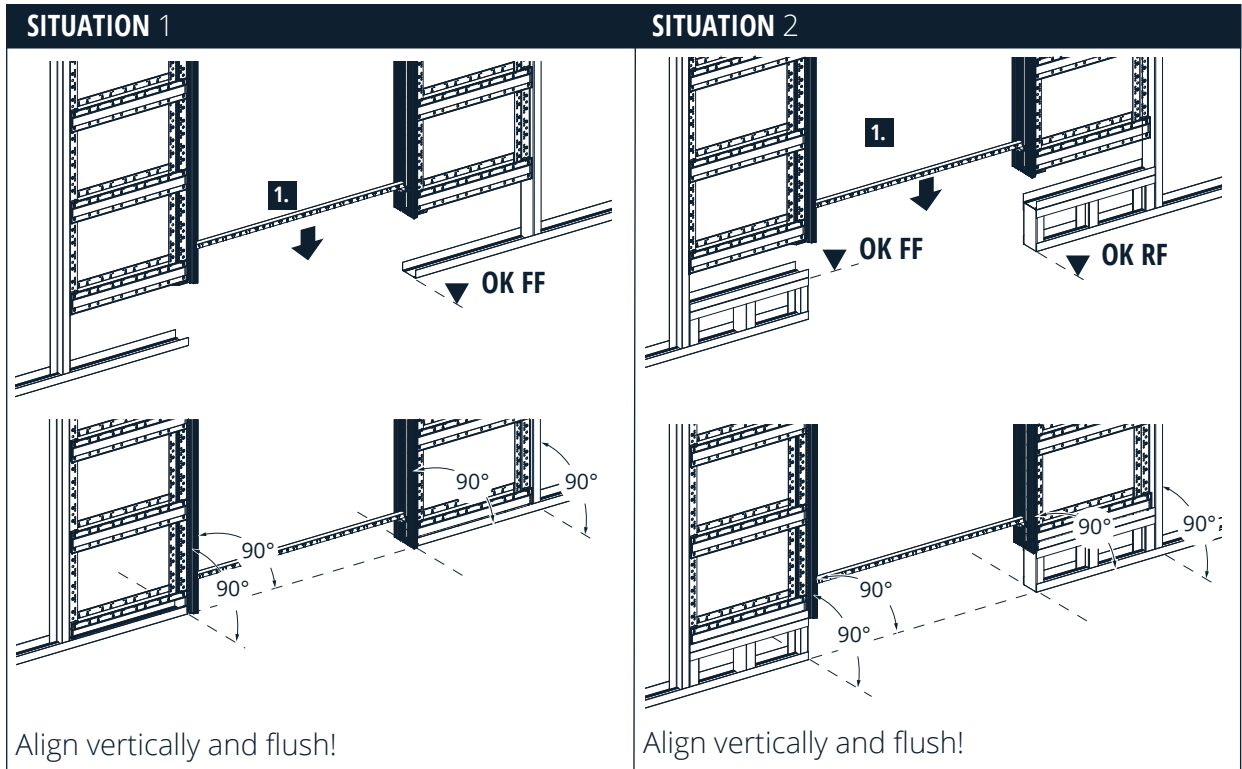

8.

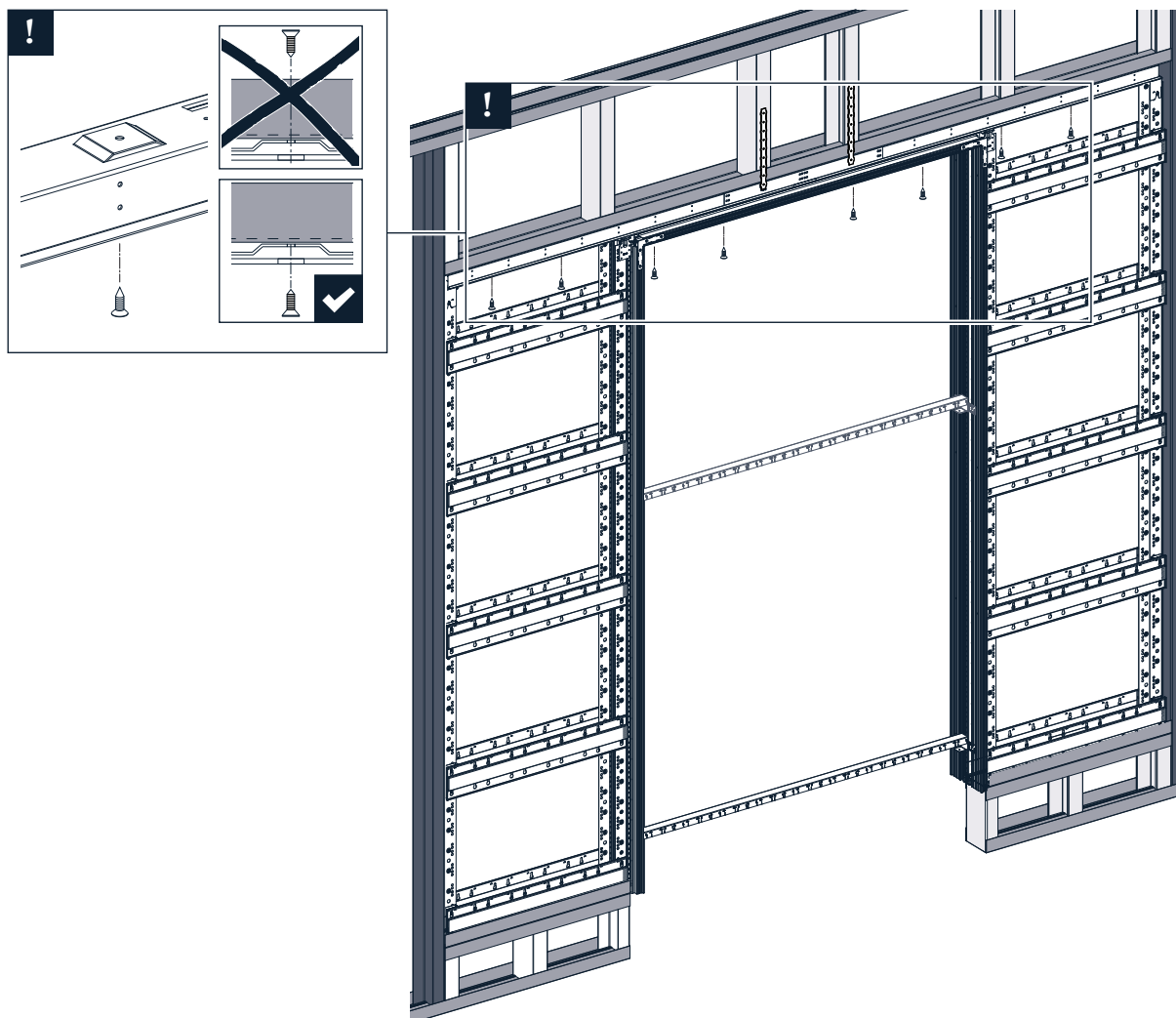

9.

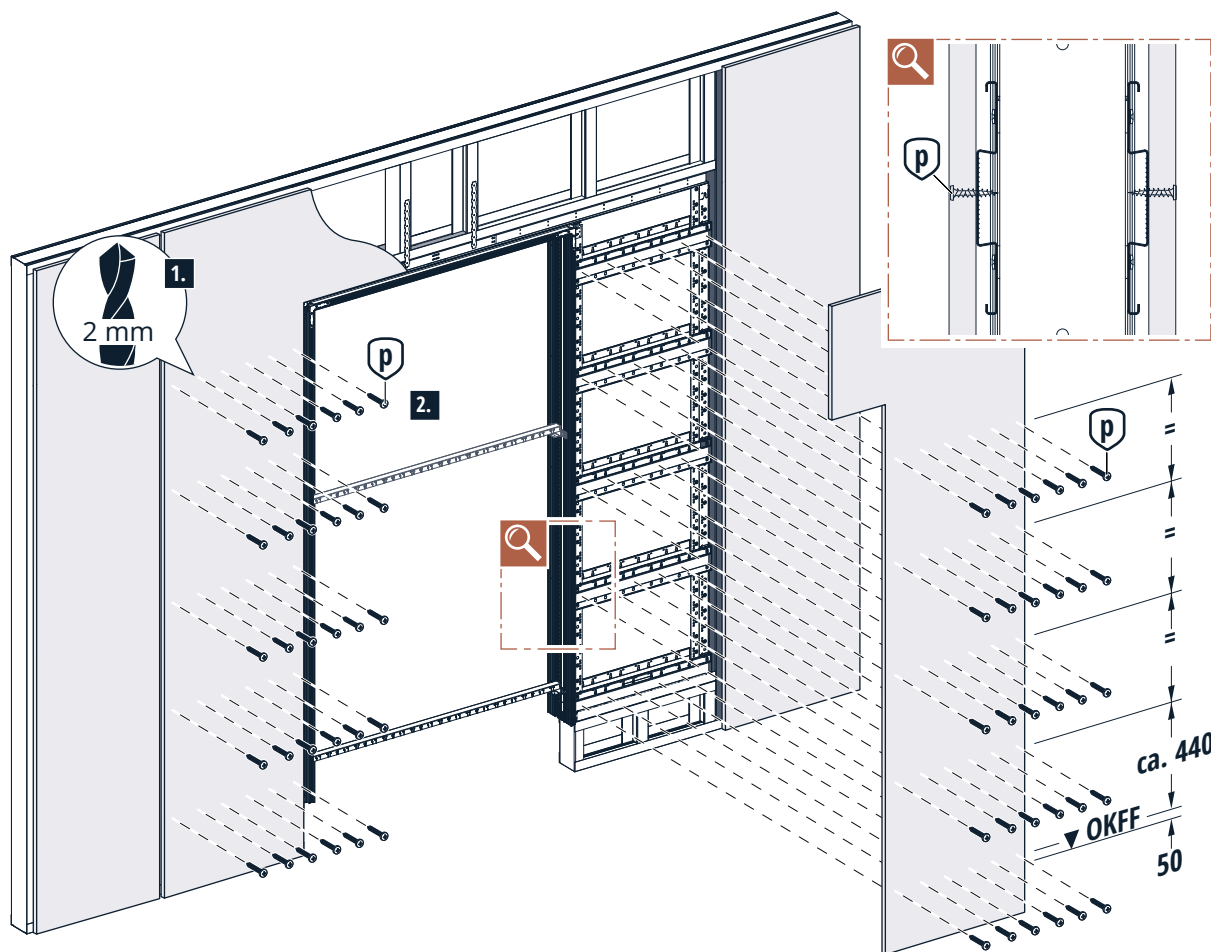

**Only use the screws supplied!**

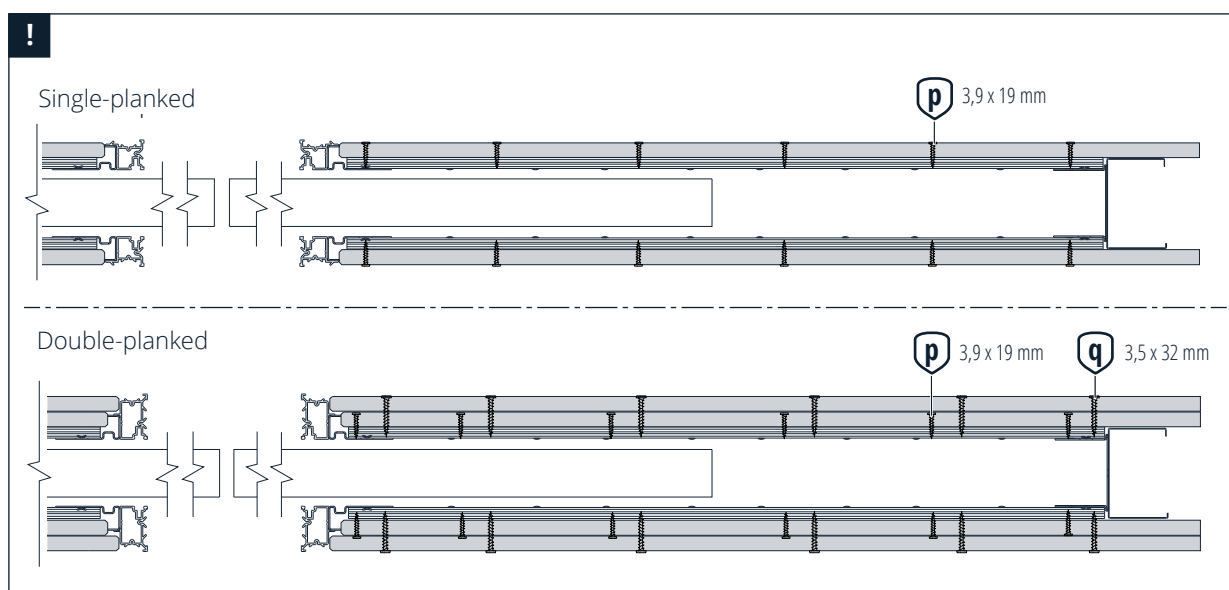

10.

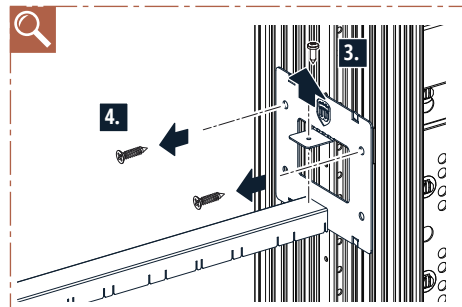
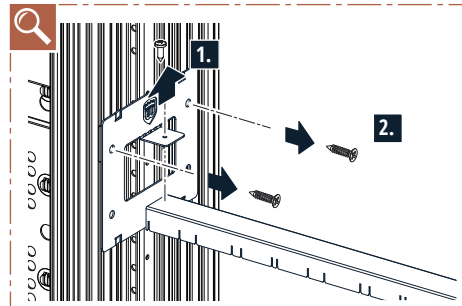
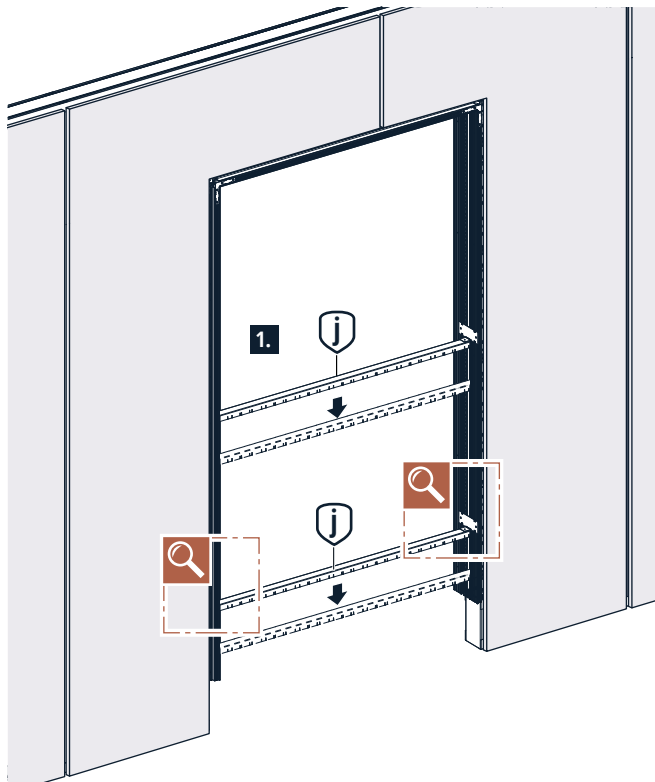

11.

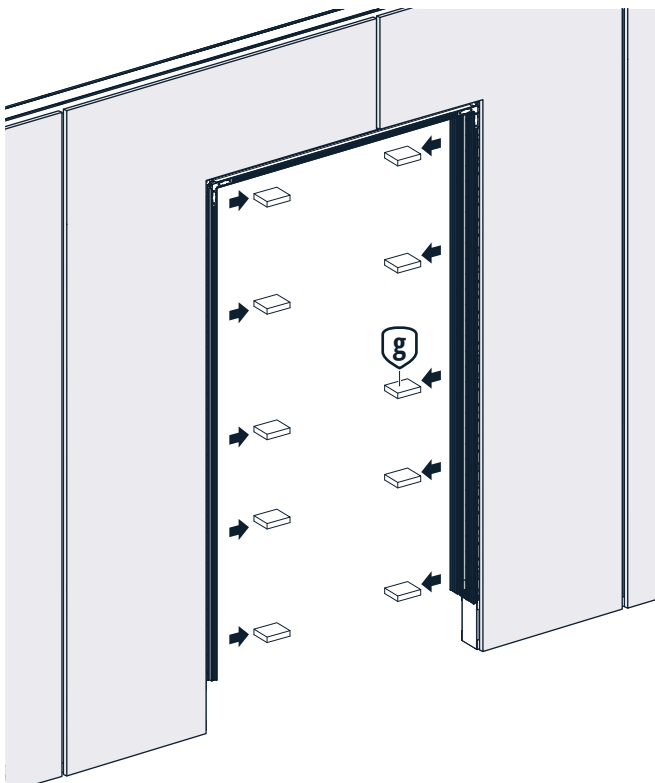

**TIP**

To remove the spacer blocks "g", use a long object, if necessary, and break them.

## 12.

---

Horizontal section

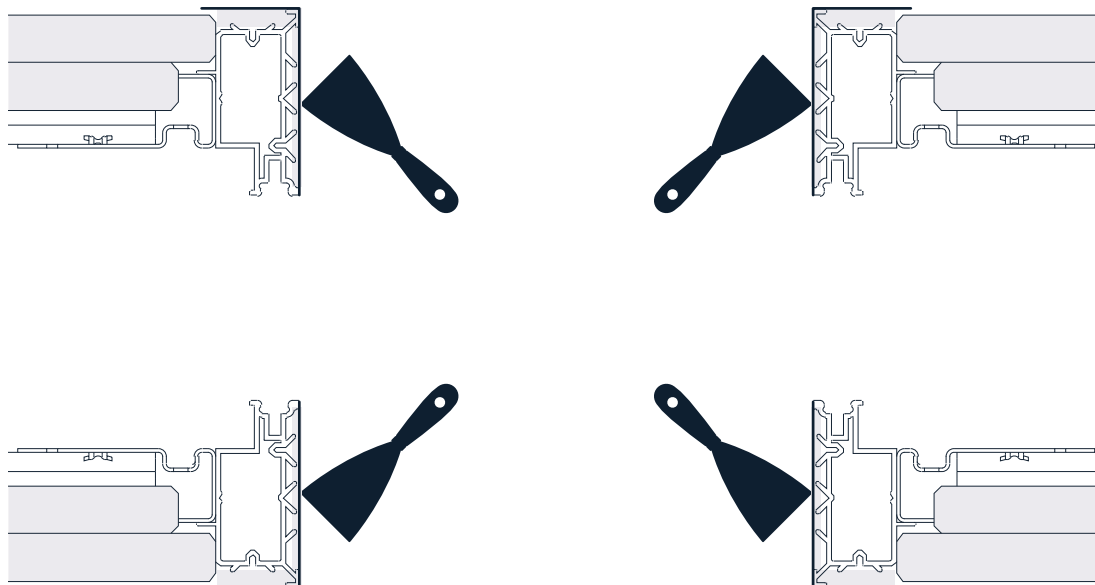

Vertical section

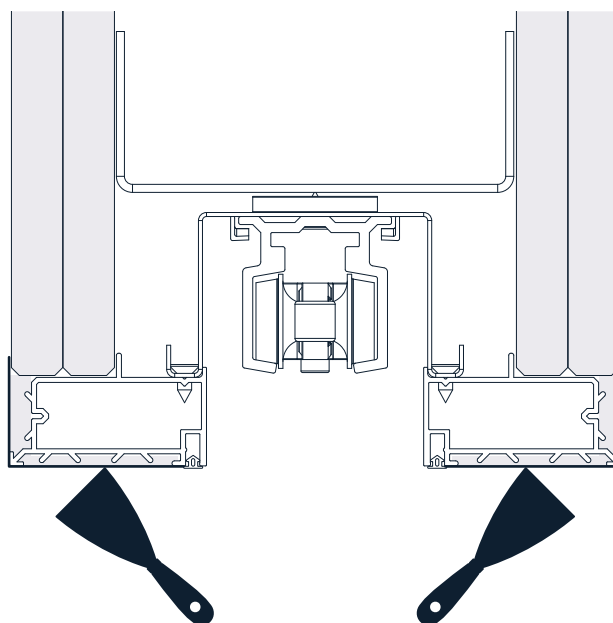





**WINGBURG**

 **+49.5257.94792-0**  
 **info@wingburg.de**  
 **www.wingburg.de**